



This manual is for reference and historical purposes, all rights reserved.

This page is copyright© by M. Butkus, NJ.

This page may not be sold or distributed without the expressed permission of the producer

I have no connection with any camera company

On-line camera manual library

This is the full text and images from the manual. This may take 3 full minutes for the PDF file to download.

If you find this manual useful, how about a donation of \$3 to: M. Butkus, 29 Lake Ave., High Bridge, NJ 08829-1701 and send your e-mail address so I can thank you. Most other places would charge you \$7.50 for a electronic copy or \$18.00 for a hard to read Xerox copy.

This will allow me to continue to buy new manuals and pay their shipping costs.

It'll make you feel better, won't it?

**If you use Pay Pal or wish to use your credit card,
click on the secure site on my main page.**

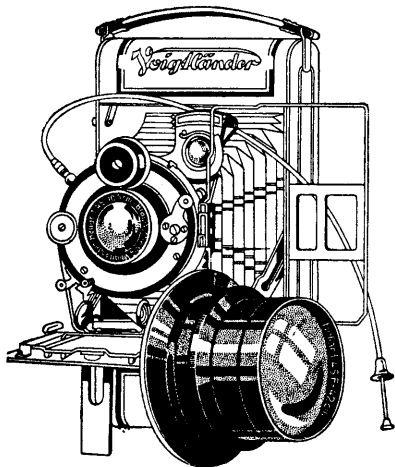

Voigtländer & Sohn
Aktiengesellschaft

Braunschweig

Vieweg A.-G., Braunschweig

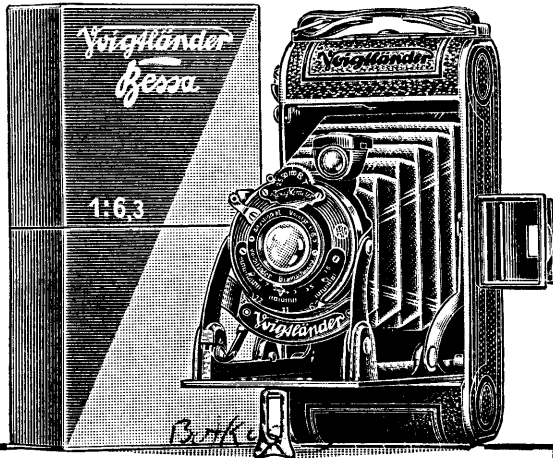

Voigtländer

Bessa *F/6.3*

Instructions for use

Nr. 2186/630 engl.

The movements, in their proper order, when using the “Bessa”, are:

The camera being loaded with film, and 1 showing in the window

- (1) Open the camera
- (2) Set the lens to Landscapes, Groups or Portraits
- (3) Set the Shutter to the required speed
- (4) Observe the picture in the brilliant or direct-vision finder
- (5) Press the release
- (6) Turn on the film to the next number

Before you begin

You are doubtless so pleased with your “Bessa” that you can hardly wait before exposing the first spool of film in order to get good photos. You may well think that these very first exposures will be good, the few movements of the “Bessa” being so simple. But few as they are, they need to be understood, and that will be the case if you will carefully read through this little booklet before putting your first film into the camera.

Essentials

A camera is essentially nothing more than a folding light-tight box, carrying a lens on the front, and, at the back, the film on which a picture in miniature of the natural scene is cast by the lens (fig. 1).

Important Note. The camera should not be closed with the shutter open at *T*, otherwise the release trigger will be bent

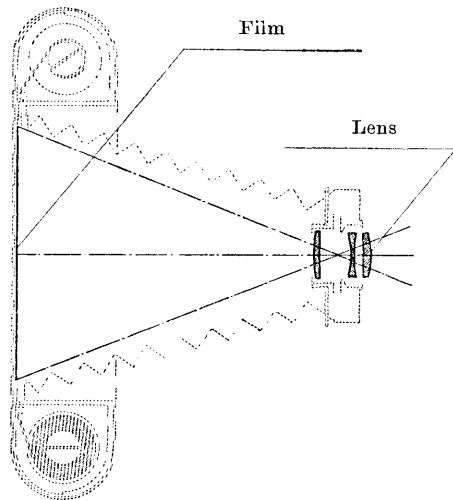

Fig. 1. How the picture is formed

Opening (fig. 2)

To open the camera, press on the button 3 seen on the left-hand side. The baseboard 5 then springs out by itself, and is gently pressed down with the other hand until the struts 9 distinctly snap into place.

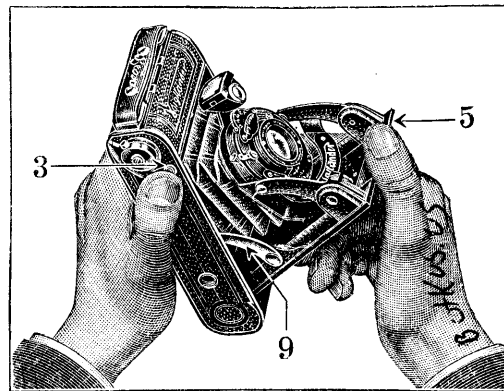

Fig. 2. Opening the Bessa

chanism, and the camera is ready for an exposure (fig. 4).

Three-point Focussing (fig. 3)

The three-point system of the Bessa immensely simplifies the taking of sharp pictures.

On the lens mount is a small pointer 15, which, by turning the lens mount, is

caused to move along the scale marked Landscapes; Groups; Portraits. Before making an exposure, the pointer is set to the appropriate word. In the case of "Landscape" and "Portrait", it is pushed as far as it will go; for "Group" it is set to the marked middle of the arrow. The designations Landscape, Group and Portrait are not to be taken altogether literally. If, for example, a figure or a building is to be photographed at a distance of about 20 ft, that is at the average distance of a group, the pointer must of course be set to "Group". In a like manner, if the subject is a still-life study or a dog at a distance of $7\frac{1}{2}$ ft, the pointer is set to "Portrait". With the $3\frac{1}{4} \times 2\frac{1}{4}$ ins Bessa, you should never be nearer to the subject than 5 ft; or 7 ft, in the case of the $4\frac{1}{4} \times 2\frac{1}{2}$ ins Bessa.

With the $3\frac{1}{4} \times 2\frac{1}{4}$ Bessa everything beyond 25 ft from the camera is obtained sharp when the pointer is set to "Landscape". If set to "Group", the region of sharpness extends from 23 to 10 ft;

and if set to "Portrait", from 8 to 5 ft. In the case of the $4\frac{1}{2} \times 2\frac{1}{2}$ Bessa, these regions of sharpness are somewhat different. At "Landscape", it is from 33 ft to ∞ (infinity); at "Group", from nearly 30 to 13 ft, and at "Portrait", from 10 to 7 ft. It is a good plan to fix these ranges of sharpness in the mind in connection with suitable objects. The distances are also engraved on the scale above the three words, so that the figures 25, 23, 10 and 8 placed between the two stops (33, 30, 13 and 10 in the case of the $4\frac{1}{4} \times 2\frac{1}{2}$) may be used also for sharp focussing when judging distances in ft. If it is wished, for example, to obtain sharpness more towards the foreground or the distance, the red pointer is set, along the scale, between "Landscape" and "Group" or between "Group" and "Portrait". But the mistake should not be made of thinking that the stop prevents the lens being focussed to nearer distances than 5 or 7 feet as these are maximum distances at which it is possible to take close up photos.

Shutter (fig. 3)

The shutter serves the purpose of keeping the lens covered and of allowing the light to act on the roll-film for a longer or shorter time only during the exposure. The "Bessa" is fitted with a

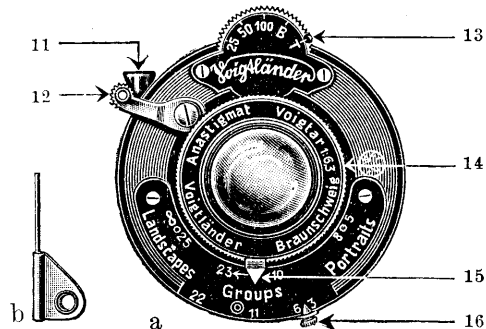

Fig. 3. Shutter, with three-point focussing

specially reliable shutter which is operated as follows:

Above the lens will be found the black scale 13 (fig. 3) engraved with the various times. Behind it is the nickelled setting disc, bearing a red button, which may be readily set with

the first finger to the chosen mark on the scale.

The numbers on the scale denote $\frac{1}{25}$ th, $\frac{1}{50}$ th and $\frac{1}{100}$ th of a second, which for the sake of greater clearness are written as whole numbers. When making an instantaneous exposure, the red button is first set against the number chosen. On now pressing the trigger 12 (fig. 3) or the flexible cable release screwed in at 11, the shutter opens, and closes at the expiry of the fraction of the second for which it has been set, the exposure thus taking place automatically.

The letter *B* on the scale is for use when giving short time exposures. The red button is set to *B*, and the shutter then opens as soon as the cable release or the trigger 12 is pressed, remaining open until pressure is withdrawn. The exposure may be timed by counting; not, however, the single numbers but the repeated formula "one little second", "two little seconds" and so on. Thus for three seconds, we repeat clearly but without pausing: "one little second",

“two little seconds”, “three little seconds”. The trigger or release is pressed at the “one”, and pressure relaxed at the end of “three little seconds”. Time expo-

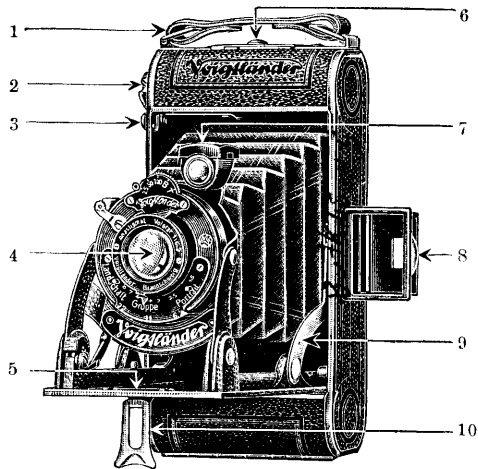

Fig. 4. The Bessa, ready for use

sure requires the camera to be firmly supported on a tripod, table etc: if the camera is held in the hand, the pictures will be unsharp owing to movement of the image on the film.

By setting the red button to *T*, the shutter opens on pressing on the cable release or the trigger 12, and remains open until one or the other is pressed a second time. This is the setting to be used when it is necessary to keep the shutter open for minutes at a time, as when taking night photographs or when making exposures by flashlight.

Distance Release

Self-portraits may be taken with the *F/6.3 Bessa*. When giving exposures of $\frac{1}{25}$, $\frac{1}{50}$ and $\frac{1}{100}$ sec, the shutter may be operated from a considerable distance by an ingenious device. A piece of wire of the shape shown at *b* fig 3 is inserted in the small aperture under the word “Group”, and then the shutter can be tensioned by pressing the trigger 12 or flexible cable without, however, opening. The exposure does not take place until the wire is pulled out, as may be done by aid of a black thread of suitable length. The most certain plan is first to lay the free end of the thread at the place where

the operator will be, then to insert the wire in the aperture and, last of all, to set or tension the shutter. For success with the distance release, it is of course essential that the camera be fixed firmly in place, preferably on a rigid tripod.

Stops

On the lower edge of the focussing scale (Landscapes; Groups; Portraits) will be seen the stop Nos. 6.3, 11 and 22, along which moves the stop lever 16 (fig. 3) by which the aperture in the lens may be reduced. In the ordinary way this lever must be set at the No. 6.3, the lens then working at its full aperture.

It is only for special purposes, *e. g.* when photographing subjects which include both a very close foreground and far distance, that the lens is stopped down, that is to say, the lever 16 put to the No. 11, or perhaps to 22. By doing this, the region over which sharpness is obtained is extended towards and away from the camera — to the

obvious advantage of the photograph. When stopping down, however, the aperture and therefore the “speed” is reduced, so that a longer exposure must be given. In comparison with the full aperture of 6.3, the exposure at 11 must be three times as long and at 22 12 times as long. This is, of course, the drawback, but an unavoidable one, to the use of the stops, and for this reason the lens should be used at 6.3 as a rule.

Finders

The *F/6.3* Bessa is fitted with two finders.

Direct-vision Finder (8, Fig. 4)

The direct-vision finder is attached on the left-hand side of the camera back. It consists of a frame and of a portion having a small aperture in it, called the “sight”. By turning up the frame on the metal pieces projecting from the camera back, it snaps into the upright position. The sight likewise comes automatically into place (parallel with the frame) by

the action of a spring (fig. 5). The correct amount of subject is now seen by so looking through the small opening in the sight that it coincides exactly with the frame. Owing to the fact that

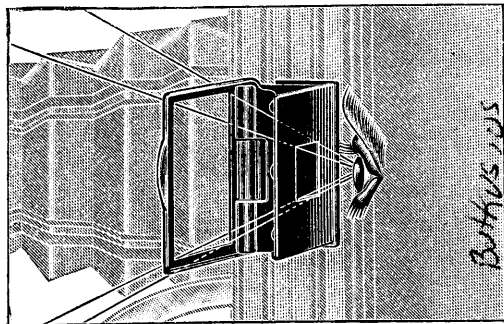

Fig. 5. Looking through the direct-vision finder

the camera is held at eye level, a most natural perspective is obtained with the direct-vision finder, and it is well to use it whenever possible.

When closing the camera, first press the sight down on to the camera back, and fold the frame over it.

Brilliant Finder

To the side of the shutter, as shown in fig. 4, is attached the brilliant finder 7.

On looking down into it from above, a miniature picture is seen of the subject to be photographed and thus allows

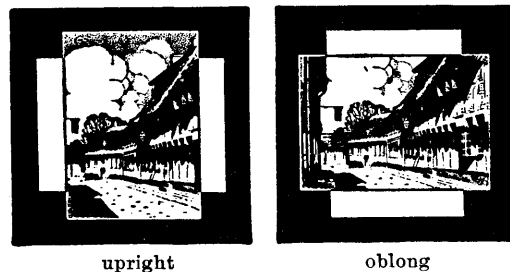

Fig. 6. Pictures in the brilliant finder

of the desired amount of subject being included.

The cut-out placed in the upper part of the finder is so devised as to show the amount of subject according as an upright or oblong picture is taken. These different selections of the subject are illustrated in fig. 6. For exposures made

oblong-way, the brilliant finder requires to be turned through an angle of 90° , so that it can still be viewed from above.

The very bright but small picture seen in the finder may be magnified about



Fig. 7. The Voigtlander FINDER Magnifier

3 times by attachment of a Voigtlander FINDER Magnifier (No. 5 for the $3\frac{1}{4}'' \times 2\frac{1}{4}''$ Bessa, No. 2 for the $4\frac{1}{4}'' \times 2\frac{1}{2}''$ Bessa), obtainable from photographic dealers (fig. 7).

By this means the amount of subject is much more plainly seen, and also the

details of the picture. The magnifier is of such small size that, when one part is thrust within the other, it may be conveniently carried in the waistcoat pocket.

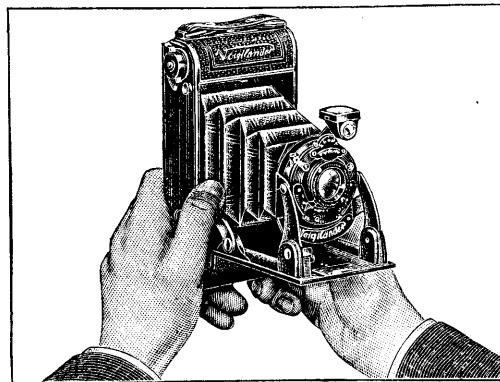

Fig. 8. Releasing the side struts

Closing the Camera

Before closing the "Bessa", always take care to see that the shutter is closed and that the brilliant finder is in its normal position (for upright pictures), otherwise injury may be done when closing.

Now take the camera in the two hands so that the first and middle fingers are extended over the camera back, whilst the lower edge of the body rests on the two third fingers (fig. 8). Gentle pressure of the thumbs on the two side

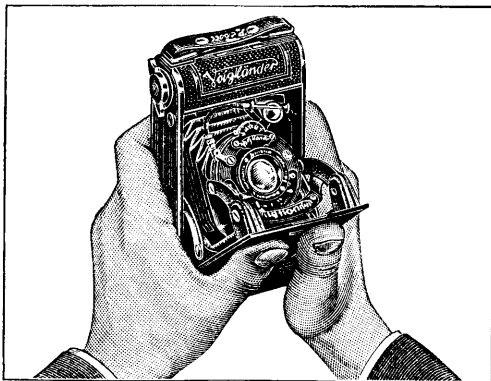

Fig. 9. Closing the baseboard

struts will then allow of these being released from their catches, so that the baseboard can be folded over on to the camera body. In doing this, the lens-front and bellows come automatically into place (fig. 9).

Loading the Bessa

Having now become perfectly acquainted with the mechanism, we can proceed to the insertion of the roll-film.

Loading, as this operation is briefly termed, may be done by daylight, as

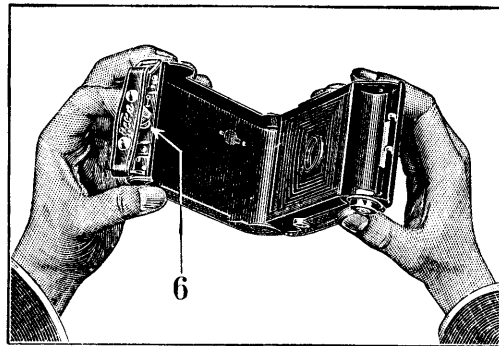

Fig. 10. Opening the film-chamber

the film itself is protected against the harmful action of light by several layers of opaque paper. Nevertheless it is of course well not to load the film in direct sunlight, but at any rate in the shadow of one's body.

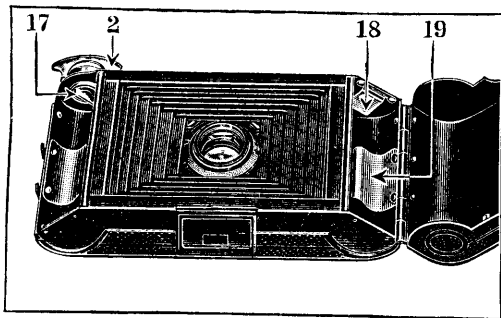

Fig. 11. Showing the film-chamber

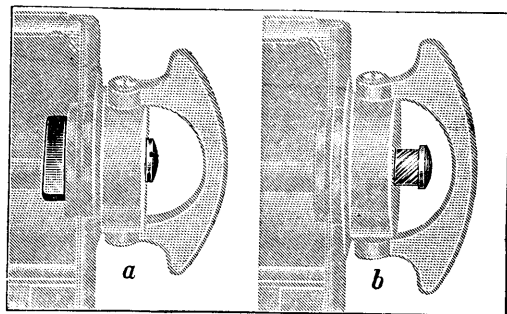

Fig. 12. Film winding-key

To open the film chambers, hold the Bessa by its short side, so that the back with the red film window is turned towards the left hand. Now with the first finger of the left hand slide the catch 6 (fig. 10) which is placed under the carrying strap, sideways in the direction of the arrow, whereupon the cover of the camera back can easily be turned on its hinges down into the open position (fig. 10).

On the upper film chamber (to receive the empty spool) is the winding key 2 (fig. 11) with the flat pin 17 by which the spool is turned when the winding key is operated. A quarter turn of the winding key to the left (backwards) suffices to bring this pin from its normal position *a* (fig. 12) into the position *b* in which it is invisible from the inside of the film chamber. The empty spool can now be inserted very easily (fig. 13), only taking care that the end of the spool with the slot in it is put next to the winding key, and that both ends of the spool are put

in simultaneously. Now give the winding key one or two turns to the right, the flat pin then springing automatically into the slot and connecting the spool with the winding key.

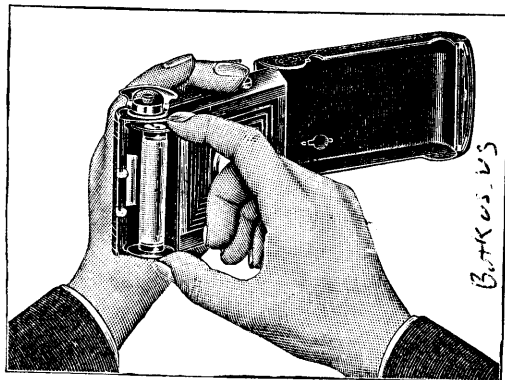

Fig. 13. Inserting the empty spool

The fresh full spool is now laid in the other film chamber (next to the hinge of the camera back), where it is held in place by the springs 18 (fig. 11). It is very important that the taper end of the red wrapping paper should project from the film chamber on the side next

to the hinge in order that the fresh spool, in unrolling, may turn in the same direction, i. e. to the right, as the empty spool is turned by the winding key.

Now tear off the white adhesive strip from the full spool with the finger nail,

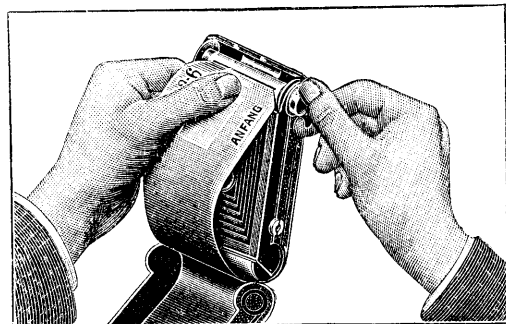

Fig. 14. Attaching the end of wrapping paper

close the camera back half-way, so that the spool cannot spring out, and draw the end of the wrapping paper over to the upper film chamber. Then insert the taper end in the **long** slit in the empty spool (fig. 14) and wind on the paper by giving about 1 or 1½ turns

to the winding key, the paper being thus stretched taut between the two spools. At the same time make sure that the paper is not askew on the spool, otherwise the film will subsequently become jammed.

All having been properly arranged, carefully close the camera back by pressing the two halves together and turn the winding key **slowly** on until (after about 15 whole turns) a hand appears in the red window in the camera back, followed by a series of dots and then the number 1. The camera is now ready for the first exposure. For the second and further exposures, the winding key is again turned so as to bring the number 2 and the others up to 6 (or 8) successively into place in the window.

Unloading the Camera

When, after the last exposure, the number 6 (or 8) is seen in the window the whole film has been exposed. Then turn the winding key until the end of the red wrapping strip has passed by in

the window and the film has thereby been wound on to the upper spool. It is not possible to over-wind in doing this.

Now turn up the camera back, as already described in fig. 10 for loading the camera. Next, hold the outer coils

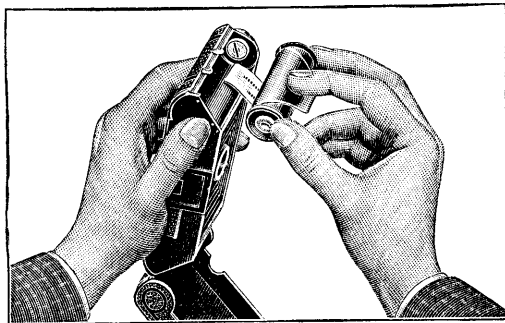

Fig. 15. Removing the exposed spool

of the red paper in place with the left hand and, with the right hand, give a few turns of the winding key until the paper is wound fairly firmly. The paper should not be wound too tightly, because the film may become marked by the friction of one coil on another. Now give the winding key a quarter turn in the reverse

direction; the exposed spool can then be readily removed from the spool chamber (fig. 15). As shown in the drawing, when doing this, hold the end of the wrapping paper firmly in place with the first finger so as to prevent the film from becoming loose in the spool. Now secure the spool with the gummed strip provided for the purpose on the end of the band. All this may be done in daylight, but of course, whenever avoidable, not in direct sunlight, but in the shadow of the body.

When packing the exposed film, it is best (presuming that a fresh spool is being inserted) to wrap it in the paper of the new spool and to put it in the carton of the latter. To prevent confusion between exposed and unexposed films, part of the package of the former should be marked in pencil.

The now empty spool in the lower chamber of the camera is now removed and inserted in the upper chamber as already directed under "Loading".

Holding the Camera

The most successful exposures are usually those which are snapped without a lot of consideration. The "Bessa" camera is made specially for this, but at the same time it is advisable to become adept in the rapid and certain use of the few movements by practice with the unloaded camera.

When opening the camera and setting the focus, adopt a firm position, for any slight wobble of the camera during the exposure will cause pictures with double outlines. When taking upright pictures, hold the baseboard with the left hand, the thumb on the lens front and the fingers on the side of the baseboard (fig. 16). When taking oblong pictures with the aid of the direct-vision finder, lay the left hand against the lower part of the camera back, whilst supporting the upper part with the palm of the right hand. If, however, the brilliant finder is being used for an oblong picture, rest the thumb of the left hand on the upper edge of the baseboard,

supporting the latter below with the four fingers.

For holding the camera specially firm, the back may be pressed against the head when using the direct-vision finder;

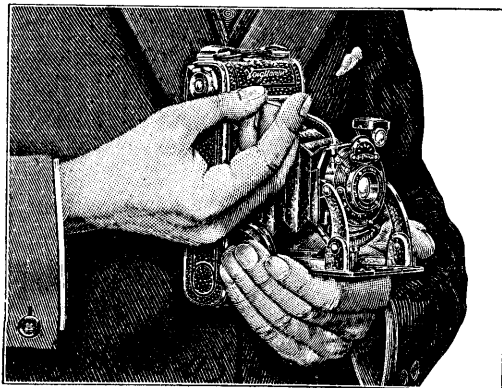

Fig. 16. Holding the camera for an exposure

for upright pictures it is placed against the forehead and nose (viewing the sight with the left eye) or, for oblong pictures, against the nose and cheek bone. When using the brilliant finder, the camera back is placed against the chest.

The best way to make the exposure is with the flexible cable, held in a wide curve (not tightly stretched), pressing smoothly on the release, not with a jerk. Exposures of $\frac{1}{25}$ sec. and less may be made with the camera held in the hand if ordinary care is taken to stand steadily.

For longer exposures the camera must be used on a firm support. It is placed on a table or other flat surface with the aid of the hinged strut 10 (fig. 4) provided in the baseboard for this purpose or is screwed to a tripod of the ordinary pattern. For use with the latter, the "Bessa" is fitted with two tripod bushes, one in the baseboard for upright pictures and the other on the side of the body for oblong pictures.

How Long to Expose

Correct exposure is a factor of prime importance in photography, but there is no occasion to be over-anxious about it. Suitable development of the film allows of a considerable latitude in the time of exposure, provided that it is

made a rule, when in doubt, to expose for a longer rather than a shorter time. The normal times of exposure at full

| A. Exposure in seconds in fine weather ¹⁾ with stop $F/6.3$ | | |
|---|---------------------|-----------|
| I. Out of doors | | |
| Landscapes | Groups | Portraits |
| $1/100$ | $1/50$ | $1/25$ |
| II. Indoors, near window | | |
| Light interiors | $1/2$ to 1 | |
| Medium lighted interiors | 2 to 4 | |
| ¹⁾ In dull weather exposures should be 2 to 4 times those given. In very dull weather exposures should be 6 to 8 times those given. | | |
| B. Flashlight exposures at $F/6.3$ | | |
| Distance of flash from subject | Flash powder grs | |
| 10 to 13 ft. | 25 | |
| 16 to 20 ft. | 30 | |
| 23 to 26 ft. | 45 | |

aperture in fine weather may be seen from the following table, and it is well to memorize these few figures as a basis. In dull weather, and also when the light becomes less bright earlier or later in the day, the exposures should be 2 to 4 times those given. The three stops call for exposures in the proportion of 1:3:12. Thus, if a second is correct with $F/6.3$, the corresponding time with $F/11$ will be 3 seconds, and 12 seconds with $F/22$.

For those who would go more closely into the question of exposure we recommend the Voigtländer Exposure Calculator, which weighs little (less than 1 oz) and is of only postcard size, so that it may be conveniently carried in the breast pocket. The advantage of this calculator over others is that there is only one sliding scale to be moved in order to ascertain the correct exposure without any computation. The exposures indicated are ample: under-exposure need not be feared.



Voigtländer Yellow Filters

Many amateur photographs are unpleasing on account of such defects as bald skies, black flowers in a meadow scene, grey fruit blossoms against a white sky,

glaringly white eyes or pronounced freckles in a portrait.

In order that your photos may render the colours of nature in their correct tone values, you should make it a rule to use orthochromatic film. But make sure that the colour-sensitiveness is not simply a question of the label. Your best plan is to ask your dealer for his experience; he will recommend you the best film to use.

The good qualities of orthochromatic film can, however, obtain their full effect only when the blue rays of light are cut down to some extent by means of a yellow filter. You will be saved from

disappointment if you choose not merely "a filter" but a reliable Voigtländer Yellow Filter.

Your dealer supplies the Voigtländer Yellow Filters in special mounts correctly fitting the lens of the Bessa. As a general rule the filter to use is the Alpha, which increases the exposure only twice and therefore allows of instantaneous exposures in many cases. The Beta filter requires five times the exposure and is for use only when a specially strong effect is desired.

In Conclusion

We should like you to obtain the best from your "Bessa" camera. As you proceed, you will attain this end most surely — at any rate at first — by entrusting the development and printing of your films to your dealer, and we recommend you to do this. Suitable development is the most reliable criterion of the mastery of the methods of taking photographs; nevertheless the taking — as we must always remember — lays

the foundation for the photographic picture. If you experience any difficulties, the dealer will gladly give you the benefit of his advice.

The Voigtländer Bessa Camera takes any make of roll-film, but for the best results you should always use

Satecap

ROLL-FILMS